



CMS is part of SCM Group, a technological world leader in processing a wide range of materials: wood, plastic, glass, stone, metal and composites. The Group companies, operating throughout the world, are reliable partners of leading manufacturing industries in various market sectors, including the furniture, construction, automotive, aerospace, ship-building and plastic processing industries. SCM Group coordinates, supports and develops a system of industrial excellence in 3 large highly specialized production centres employing more than 4,000 workers and operating in all 5 continents. SCM Group: the most advanced skills and know-how in the fields of industrial machinery and components.

CMS SpA manufactures machinery and systems for the machining of composite materials, carbon fibre, aluminium, light alloys, plastic, glass, stone and metals. It was established in 1969 by Mr Pietro Aceti with the aim of offering customized and state-of-the-art solutions, based on the in-depth understanding of the customer's production needs. Significant technological innovations, originating from substantial investments in research and development and take-overs of premium companies, have enabled constant growth in the various sectors of reference.



**CMS Stone Technology** realizes avant-garde solutions for the working of marble, natural stones and composite stones. Under the brand name Brembana Macchine, CMS Stone Technology was in the 80's the first manufacturer of a stone machining centre, thanks to an idea of its founder Mr Pietro Aceti. **CMS Stone Technology** has always been a reliable technological partner in designing unique solutions, for any need, in the world of building, architecture, interior and exterior decoration and wherever the use of stone and marble products is required.

# waterjet

<b>APPLICATIONS</b>	4-5
<b>WATERJET MACHINES FOR PROCESSING MARBLE</b>	6-7
<b>BREMBANA EASYLINE - BREMBANA MILESTONE S - BREMBANA PROLINE - BREMBANA AQUATEC TECHNOLOGICAL ADVANTAGES</b>	8-15
<b>WATERJET MACHINE CONFIGURATION STANDARD/OPTIONALS</b>	16-23
<b>PRESSURE MULTIPLIERS</b>	24-29
<b>EASYJET DDX SOFTWARE</b>	30-31
<b>BULK AND TECHNICAL DATA</b>	32-37
<b>CMS CONNECT / ACTIVE</b>	38-39
<b>THE GROUP</b>	40-41
<b>THE RANGE</b>	42-43



# APPLICATIONS



**Unparalleled.**  
**New.**  
**Innovative.**  
**Quality.**  
**Ultra.**  
**Effective solutions.**

bathroom and kitchen tops | ventilated facades | inlays and mosaics | flooring



flooring | fireplaces | urban furnishings | doorsteps, staircases and windowsills

The **UNIQUE** waterjet cutting machines.

Waterjet cutting systems

# WATERJET MACHINES FOR PROCESSING MARBLE

**BREMBANA EASYLINE:** the solution with a more flexible arm and excellent accessibility for abrasive waterjet processing



**BREMBANA PROLINE:** the most advanced technologically integrated solution to guarantee precision and repeatability to the top-end of the industry



**BREMBANA MILESTONE S:** the starter integrated solution for the marble worker's studio



**BREMBANA AQUATEC:** the sturdiest modular gantry solution on the market for swing processings



# BREMBANA EASYLINE

## TECHNOLOGICAL ADVANTAGES

### 3- AND 5-AXIS WATER JET CUTTING SYSTEM

Tecnocut Easyline is a high-performance, versatile, modular water jet cutting system - either pure or hydroabrasive - which can be employed in a number of application fields for the most diverse production demands.

- The cantilever structure, with a separate tank, allows an easy access to the worktable. Loading and removing material is quick and easy.
- All axes' motions are carried out through hardened and ground rack and pinion.
- The thermowelded bellows provide complete protection of the guides and the rack from water and dust.
- The steel structure undergoes an anti-rust treatment through sandblasting and ceramic painting, which results in a higher resistance against corrosion.
- The tank is set up for the installation of a dredge system for the abrasive removal.



### KEY BUYER BENEFITS

- + Easy operation: the cantilever structure with separate catch tank offers easy access on 3 sides to load and unload the material.
- + Easy maintenance: The tank with special anti-rust ceramic painting is designed to fit the new Evo4 chain dredge for exhausted abrasive removal even later after installation, with 91% less maintenance costs.
- + Easy sealing: The heat-sealed bellows provide complete protection of linear guides and racks from dust and water during the cutting, guaranteeing long lifetime without affecting the cutting quality.
- + The versatility of waterjet to cut a wide range of materials, with custom solutions to increase the productivity up to 55%, like single or double tank pendulum cycle or the multiple cutting heads configuration.



Console on a mobile trolley with 21.5" touch screen.



Light barriers: protection of work area with photocell devices.



Remote control up to 6 axes that allow you to operate close to the cutting surface and set multi-origins.

# BREMBANA MILESTONE S

## TECHNOLOGICAL ADVANTAGES

### 3- AND 5-AXIS WATERJET CUTTING SYSTEM

Brembana milestone s is an advanced, versatile, high-performance waterjet cutting system – either pure water or hydro-abrasive – able to accommodate the most diverse production demands in different application fields, delivering highly accurate cuts even in 3D.

- The bridge structure with fixed table, mobile crossbeam and high guides make it compact and able to move quickly
- All motions are carried out by tempered ground rack, driven by brushless motors
- The axes' guideways are housed within the structure and protected by an innovative system called "Powder-Free", which provides full protection against water and powders



### KEY BUYER BENEFITS

- + Unparalleled cutting performance: The monolithic structure with electric gantry offers a solid, sturdy solution that can guarantee a speed of 40 m/min and accelerations of 2m/s<sup>2</sup> to the top-end of market standards.
- + The most compact solution on the market with limitless rotation that guarantees a 33% reduction in the nesting cutting cycle by eliminating the need to recover C-axis rotations to align the wires and pipes.
- + A labyrinth-arranged system of painted sheet metal panels protects the linear guides and racks from the effects of dust and water dispersion during the processing.

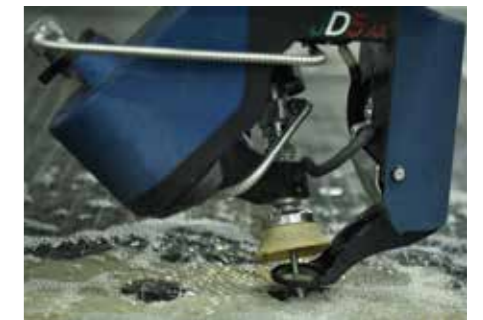

New Z-axis strokes up to 350 mm for 3 axes and up to 200 mm for 5 axes.



Hardware and Software control of the waterjet cutting system designed to offer the operator a simple and intuitive interface that allows for complete control of all the system functions, including the tapering control (JDC) for 5-axes machines.

# BREMBANA PROLINE

## TECHNOLOGICAL ADVANTAGES

### HYDRO-ABRASIVE WATERJET CUTTING SYSTEM

A genuine machining center, designed with specific solutions for waterjet technology to the extent that it guarantees superior technological performance.

Tecnocut Proline features a stainless-steel base for dredge removal of used abrasive material, automatic water level and rotating axes for processing pipes. This newly designed structure allows for the motor of the abrasive material and pressure intensifier normally installed on the ground to be built in. This brings with it the considerable advantage of reducing the overall bulk.

The gantry structure can guarantee maximum reliability over the years, thanks to tempered and ground racks and spiral pinions combined with reducers that have a movement of less than 1 arcmin.

The racks and sliding guides on the axes are protected by CMS' revolutionary "Powder-Free" system that is an engineering masterpiece of an impenetrable labyrinth of casings that guarantee full protection against water and dust.

- **more versatile:** endless standard arrangements to adapt to new production requirements
- **faster:** NC and digitally activated to speed up the programming of the machine and its accessories
- **more compact:** all the accessories are built into the base structure for fast, easy installation
- **simpler:** reduced installation times and re-commissioning

### KEY BUYER BENEFITS

- + -35% less space taken up on the floor thanks to the control systems like the motor of the abrasive material and the high-pressure electric actuator being built into the base.
- + Standard fitted system for housing the optional extras like the dredging system to remove used abrasive material and water level adjustment to adapt the plant to the client's growing production needs
- + 0.035 mm of positioning precision and +/- 0.025 mm of repeatability to guarantee cutting quality and accuracy



### RACKS AND SPIRAL PINIONS

The X and Y axes have tempered and ground racks and spiral pinions to guarantee high dynamic performance while maintaining high precision positioning standards and repeatability thanks also to the reduction of reversal movements.



Front and rear hatch with pneumatic movement to better protect the cutting area and reduce the dispersion of water and abrasive material.



21.5" industrial PC Panel on the machine with touch display and HMI CMS Active interface.

# BREMBANA AQUATEC

## TECHNOLOGICAL ADVANTAGES

### 3- AND 5-AXIS HYDRO-ABRASIVE WATERJET CUTTING SYSTEM

Brembana aquatec is an advanced, versatile, high-performance abrasive waterjet cutting system, able to accommodate the most diverse production demands in different application fields, delivering highly accurate cuts. The machine consists of a mobile bridge moving along separate high-thickness steel supports, fastened to the floor and providing outstanding structural rigidity. This structure delivers high performances even by the most demanding tasks.

- The motions - including the one of the cutting head - are carried out by high precision tempered ground rack, driven by brushless motors.
- Steel guards and the polyurethane bellows protect all motion components from water and powders.
- Loading and unloading the material is fast and simple thanks to 2 or 4 open sides, as well as checking the cutting process. Moreover it allows to possibly install additional equipment to handle the material.

### KEY BUYER BENEFITS

- + Unmatched cutting performance: the open frame structure with electric gantry on two separate thick supports on a basement anchored to the floor offer high rigidity even with rapid speed up to 54 m/min and acceleration up to 2 m/s<sup>2</sup>.
- + The most compact solution on the market with infinite rotation 33% less cutting cycle avoiding to recover the revolutions of the C axis to align internal wires and tubes.
- + Access of worktop from 4 sides: excellent access to the cutting area, the large gantry and modular frame allow configurations with wide space around the catch tank for easy loading and unloading operations.
- + High flexibility to maximize the productivity: the modular structure of frame and catch tank offer high flexibility for most demanding customers looking for large format heavy duty cutting solutions.



Console on a mobile trolley with 21.5" touch screen.



Remote control up to 6 axes that allow you to operate close to the cutting surface and set multi-origins.



Maximum configuration flexibility thanks to the modular structure.



# WATERJET MACHINE CONFIGURATION

## STANDARD

### MACHINING TABLES



Standard grate



Anti-reverberation table with sheet metal plates available in 35 or 70 mm (optional)



### 3-AXIS HEAD

The cutting head has been designed to achieve high performance when cutting. The components of the cutting head like the opening, wear insert and focusing device are perfectly aligned and auto-centered to guarantee fast replacement. The end part of the head can be changed for pure or hydro-abrasive waterjet cutting and provide maximum performance in both applications.



Electronic hopper that automatically controls the abrasive flow. If the abrasive flow is interrupted for any reason, the system will automatically stop cutting to prevent damage and scrape materials. In addition, a vacuum sensor connect to the mixing chamber constantly detect the abrasive amount and flow, providing complete real-time information on the state of wear of the cutting head.

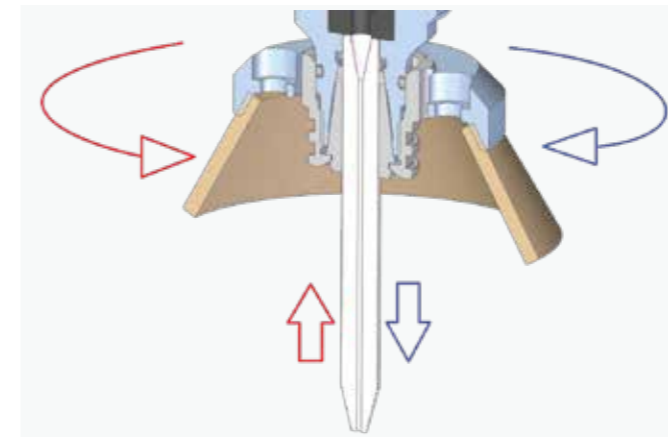

### SELF-CENTERING OF THE FOCUSING DEVICE

Thanks to CMS' experience in the electro-spindle sector, the focusing device does not need to be aligned with each replacement, because it is held by a high-precision self-centering petal clamp. Replacing the focusing device is done manually in a few seconds without tools and production is not interrupted.



### LUBRICATION

Forced injection CNC controlled automatic lubrication of the main axes X, Y and Z numerically controlled at pre-set intervals, without manual intervention and without machine down time. The presence of sensors allows for the pressure to be controlled and the tank's minimum level to be noted.

# WATERJET MACHINE CONFIGURATION

## OPTIONALS

### JD5AX



JD5ax's features open up new cutting opportunities on a wide range of materials, maximizing the operational flexibility of the 5-axis Waterjet CMS systems and ensuring very high standards of accuracy and quality of pieces obtained by an abrasive waterjet. With the innovative JD5ax head it's possible to get lower value of conicity, ensuring high finishing quality and size tolerance. JD5ax is made of an infinite rotation axis (C), an entirely new feature, and a tilting axis (B) up to +/- 62°, all designed and produced by the CMS engineers.

#### SPECIFICATIONS

- Compact design
- Cutting from 0° to 62°
- Automatic taper compensation (JDC)
- Patented abrasive injection
- New touch probe with incorporated anticollision detection
- Infinite HP joint rotation
- Compatible with the latest orifices
- Reduced mechanic components subjected to fatigue
- Monitoring of cutting components wear
- Direct drive servomotors

#### BENEFITS

- Infinite rotation for nesting cut without breakpoints
- High positioning accuracy
- High mechanical strength
- High cutting speeds and accelerations
- Taper compensation up to 60° tilt angle
- 3D machining
- Possibility to carry out countersinking and chamfering for ready-to-weld profiles
- Easy maintenance



#### DREDGING SYSTEM

Dredging system for "no maintenance" abrasive removal. The removal system inside the tank is protected both by baskets for collecting scraps and by a metal cage. The tank is ready to install a dredge system for the abrasive removal.



#### CROSS LASER

Cross laser pointer to simplify the setting of one or more points of origin of work commencement on the sheet positioned on the cutting table.

# WATERJET MACHINE CONFIGURATION

## OPTIONALS



### CLEANING SYSTEM OF THE CUT PIECE

Cleaning system for the work area which reduces the chances of scratches on the cut piece. It also enables the feeler to detect correctly the thickness of the material.



### WATER LEVEL

There is an automatic water level adjustment system inside the base. Using compressed air, the water level in the tank can be increased to 50 mm so a submerged cut can be made on the material loaded on the cutting table, guaranteeing a reduction in noise and water dispersion into the work area. A sensor fitted inside the base ensures accurate positioning of the water level above the surface of the piece without operator intervention.



### PRESSURIZED ABRASIVE FEEDING SYSTEM 330 KG

Pressurized abrasive feeding system with two 330 kg double stage tanks. The structure anchored to the base eliminates positioning and installation problems guaranteeing a constant and stable feeding of abrasive garnet into the electronic mini hopper. The double stage configuration allows for the main tank to be filled while the machine is processing.



### AUTOMATIC HOSE REEL

Air and water sprayer kit to clean table and material after the cut.

# WATERJET MACHINE CONFIGURATION

## OPTIONALS

### ACCESS THE LOADING PLATFORM

Possibility of rotating the tank by 90° by extending the Y-axis base travel runway modules to provide greater access space around the worktable and facilitate the loading and unloading of the material.

Alternatively, it is possible to configure the machine with a crossbeam up to 6 meters cutting envelope, guaranteeing a large front loading and unloading area, simplifying material handling with forklift trucks or crane.



### AUTOMATIC TCP DETECTION

Automatic cutting head alignment laser detection system with regard to the C axis and B axis rotation center for the purpose of:

- compensating the misalignment of the cutting head in the event of a strong collision
- calculating the XY positions on the focusing device precisely before performing processings with particular requirements of narrow tolerances. The device is housed on a tray hidden in the base that can be automatically removed on a guide with ball runner blocks to guarantee reliable and accurate measurements

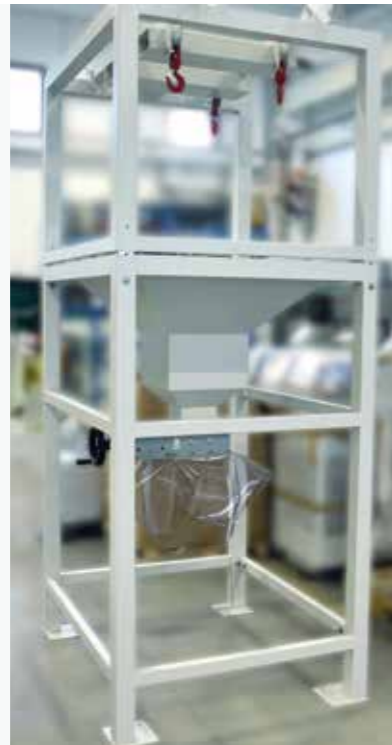

Pressurized abrasive feeding system with 330 kg capacity equipped with two tanks: one with a 330 kg capacity and another – pressurized – to supply the cutting head (electronic hopper). It is also available a 2-stage abrasive feeding system with a 2000 kg capacity to complete long cutting jobs without interruptions due to a lack of abrasive.



Cutting table electrical cabinet air-conditioning unit for room temperatures of between 35°C and 40°C (opt).

# PRESSURE MULTIPLIERS

## BREMBANA JETPOWER EVO

The hydraulic multiplier with the maximum reliability and robustness thanks to the parallel cylinder configuration



## BREMBANA GREENJET EVO

The innovative electric pump with low consumption and maintenance costs to maximize productivity under any working condition

# BREMBANA JETPOWER EVO

## PRESSURE MULTIPLIERS

### PRESSURE INTENSIFIER ENTIRELY MADE BY CMS

CMS brought about a new concept in ultrahigh pressure intensifiers, enhanced by technological solutions designed to satisfy the needs of most demanding users. This new technology is based on an intensifier equipped with several pressure multipliers independent, parallel and electronically synchronized. This innovative solution results in an everconstant pressure avoiding any drops typical of traditional opposecylinder intensifiers.

### KEY BUYER BENEFITS

- + Hydraulic intensifier with 2 or 3 independent and electronically synchronized parallel cylinders to guarantee a constant signal of output pressure without the use of attenuator.
- + The technology with 3 independent cylinders allows the bypass of a single cylinder that needs maintenance, while the machine is working, avoiding unnecessary downtime.
- + The parallel cylinders architecture is designed for a low cycle frequency that reduce the high pressure components wear and consequently the maintenance costs.
- + Reduction of oil consumption and operating costs: Water flow rate up to 5 l/min to satisfy a wide range of cutting applications, adapting the oil consumption thanks to an independent variable flow pump for hydraulic circuit.

fig. 1 Traditional opposing-cylinders intensifier

fig. 2 CMS parallel cylinders intensifier

Pressure

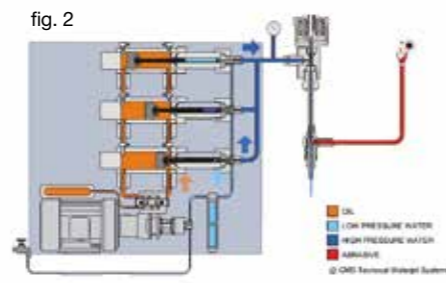
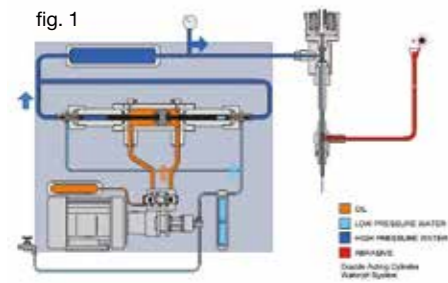
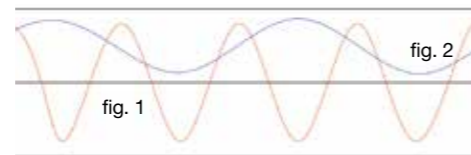

Software-based electronic control of cutting pressure

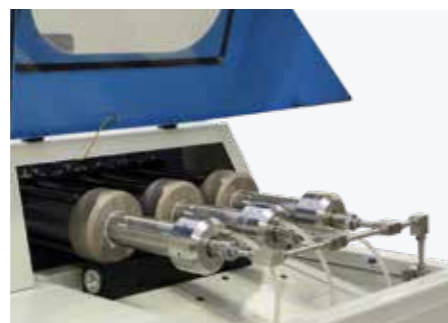

Pressure multipliers



Hydraulic unit



Oil/air heat exchanger

# BREMBANA GREENJET EVO

## PRESSURE MULTIPLIERS

### THE HIGHEST LEVEL OF EFFICIENCY WITH MAXIMUM SAVING

Tecnocut Greenjet Evo is the revolutionary high performance electric pump; thanks to an extremely efficient servomotor torque, the pressure signal is extremely high, eliminating the hydraulic control unit and reducing its components by 80% compared to a more traditional hydraulic intensifier. Tecnocut Greenjet Evo has been designed with the use of an electric driver actuator and two opposing high pressure cylinders. The electric driver technical solution guarantees an extremely steady pressure signal, a pressurisation cycle monitoring and an operating efficiency that is at least 30% higher compared to the hydraulic intensifiers.

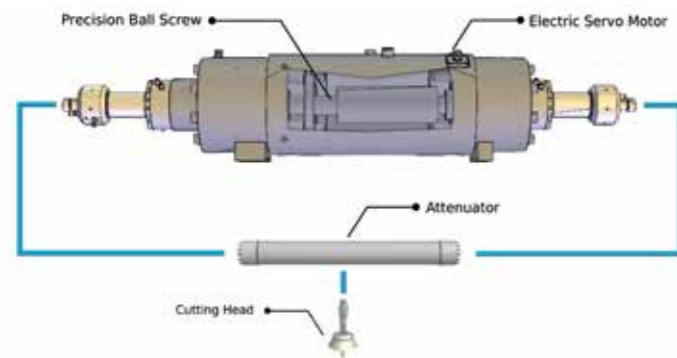

Double-acting pressure multipliers, electrically driven, manufactured with materials highly resistant against mechanical stress and corrosion.



### KEY BUYER BENEFITS

- + Electric pump actuated by a brushless servomotor capable of generating a constant pressure signal with an efficiency greater than 35% compared to traditional hydraulic intensifiers.
- + Reduced environmental impact: The electric actuator generate the high pressure without the hydraulic components with the advantage to avoid the disposal of the exhausted oil typically 200 liters every 2000 h.
- + Less than 81% of hydraulic and mechanic components and 73% less intensifying cycle than a direct drive pump, with consequently less maintenance costs and machine downtime.
- + 33% less power consumption than a traditional hydraulic intensifier thanks to precise power control of the motor when required and setting down near to zero when the cutting head is closed.



#### CONTROL PANEL

Near the electric pressure intensifiers it's available a 4.3" touch panel to set the running parameters during service operations and hydraulic and high pressure diagnostic.



#### HEAT EXCHANGER

Air/oil heat exchanger for working environments with a temperature up to 30°C. The solution allows for the consumption of water typical of water/oil cooling systems to be reduced, keeping noise levels down while operating.



#### SERVOMOTOR

The high pressure is generated by the movement of a recirculating screw driven by a female screw directly keyed on a direct drive torque motor controlled by an inverter for less wear and greater performance.

# EASYJET DDX SOFTWARE

Easyjet is a complete CAD/CAM suite for all-round management of every aspect of the 3 and 5-axis waterjet machining, that eliminates purchasing costs, maintenance and training of further third-party software products.

## THE GENERAL FUNCTIONS INCLUDE:

- Graphic management of the zoom and shift tools
- 3D and photo-realistic rendering of the project
- Functions to measure the profile and analysis of the individual entities
- Functions to delete and reset the most recent operations
- Option to configure the parameters database on-line to share it with numerous software stations
- Automatic e-mail management to request assistance
- Python Module and Scl included to customise software and interface with other systems

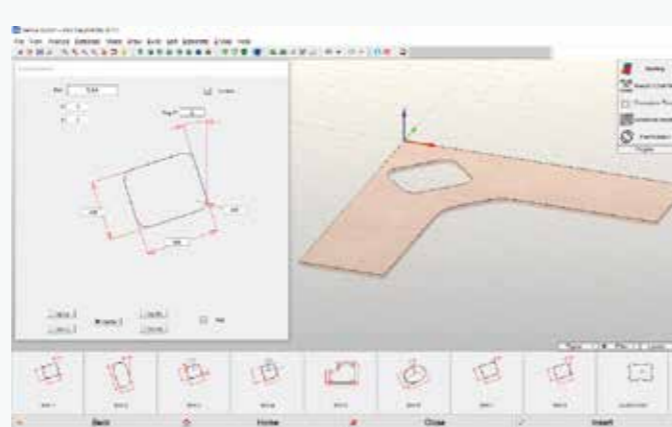

## THE CAD FUNCTIONS INCLUDE:

- Free drawing of geometrical entities like arches, lines, polylines, rectangles, squares, ellipses, circles, regular polygons, radii, clippings, nurbs, etc..
- Advanced surface drawing (loft, swept, polimesh, gordon) curve grid surface drawing
- PNT importing
- Definition of the surface using a point file elaborated by a laser scan
- Interactive change of surfaces, even complex ones, to insert chamfers, trimmings, insertion of sloping sides etc..
- Definition of construction tables
- Associating different colours to each tool path
- Change and elaboration of projects (shearing, extension, sub-division, union, interpolation, duplicate, symmetrical, rotation, deletion, etc.)
- Importing DXF, ISO, IGES, STEP, PARASOLID, 3DM and STL files
- Dimensioning

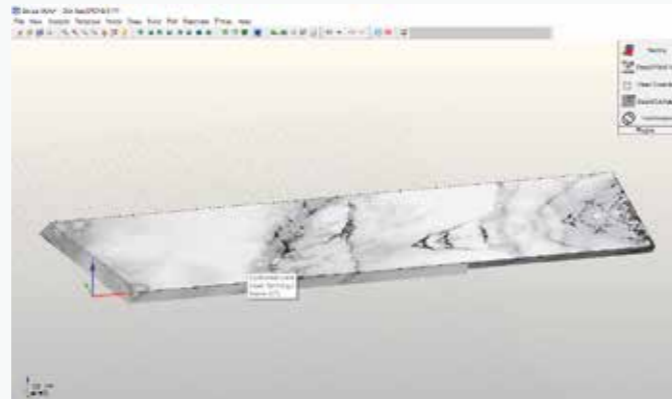

## THE CAM FUNCTIONS INCLUDE:

- Automatic generating of cutting paths with WaterJet head
- Automatic generation of input and output paths, boring included with interactive graphic change (optional)
- Continuous automatic management of the feeling cycles, at the start of the profile or the sole detection of the plate thickness
- Interpolated 5-axis control + 1
- Estimating project times and costs.
- Production of the ISO program optimised for the CNC
- Cutting management in common with the different algorithms to optimise the tool path
- Cutting with semi-automatic technology in the space.
- Automatic and/or custom-designed optimisation of the machining sequence to reduce cycle times.
- Automatic and/or manual management of the micro-joints and bridges.
- Cam-Auto module to automatically and intelligently create machining technology

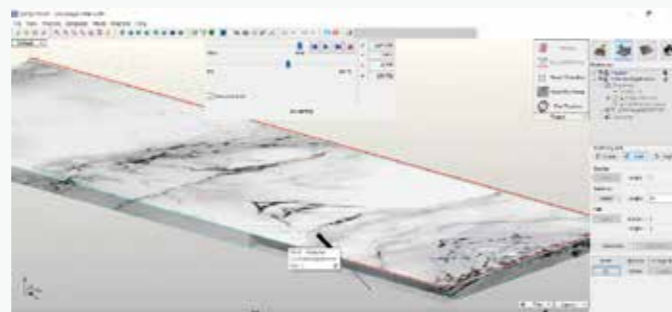

In addition, the Easyjet software has powerful, fast multiple nesting algorithms in the work area, even with entities that differ from one another, with the possibility of graphically changing the arrangement of the objects and defining customised points of origin.

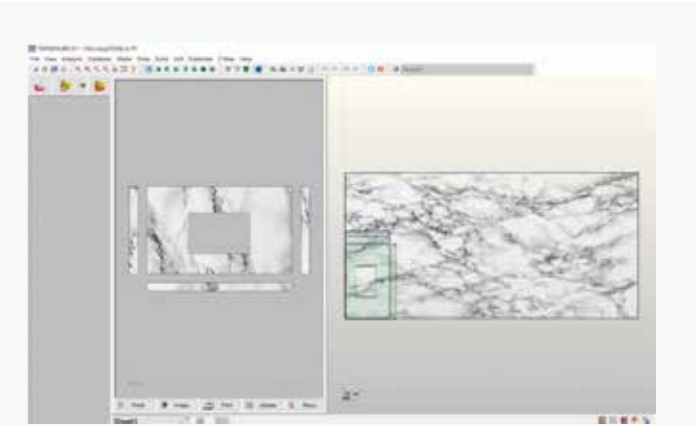

Quality	Upper diameter	Lower diameter	Feed
Low	1.05	0.5	1639.6024
Medium-low	1.1	0.55	747.8917
Medium	1.15	0.6	468.1757
Medium-high	1.2	0.65	337.0262
High	1.3	0.90	263.7411
Extra	1.37	1.02	211.4224

The JDE plug-in is included in the package to manage the cutting technologies archived in a complete materials database. The machine program is automatically generated on the basis of the selection of the cutting quality required out of 5 options (Q1, Q2, Q3, Q4 and Q5) that establish the speed advancement and acceleration settings in the internal/external corners. The ISO program can then be transferred to the machine using the local network or via USB drive.

The correct setting of the machining parameters can be checked in advance thanks to the 3D simulation of the machining process using a 3D graphic model of the CNC that reproduces the table, handling axes, tool and piece arranged on the table.





# BREMBANA EASYLINE

## BULK AND TECHNICAL DATA

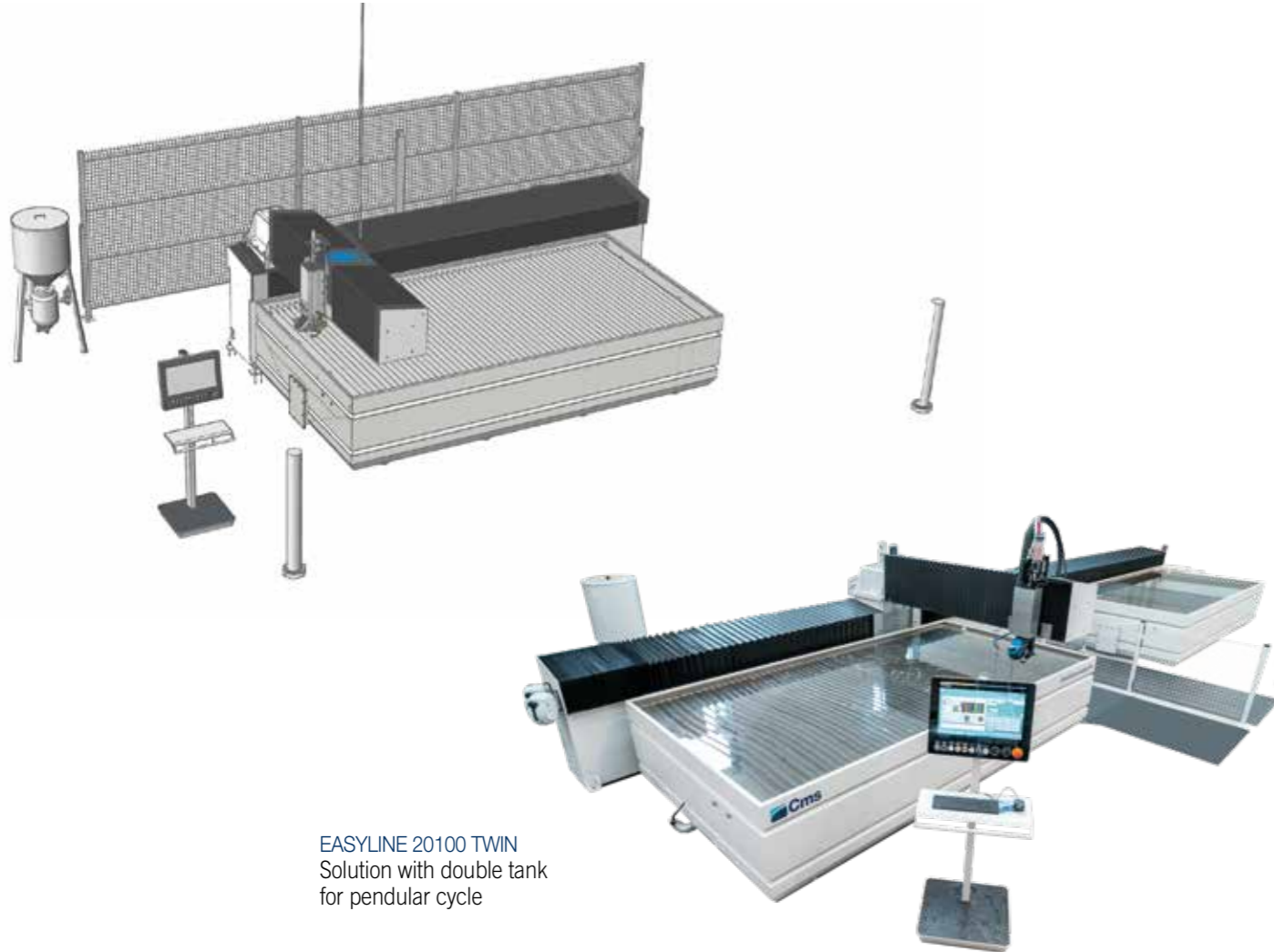

BREMBANA EASYLINE: TECHNICAL DATA			
MODEL	2040	2060	20100 TWIN
X AXIS	4000 mm	6000 mm	11250 mm
Y AXIS	2000 mm	2000 mm	2005 mm
Z AXIS	220 mm (150 mm with 5-axis head)	220 mm (150 mm with 5-axis head)	150 mm with 5-axis head
B AXIS	+/- 60°	+/- 60°	+/- 63°
C AXIS	-	-	infinito
SUPPORT PLANE	4210 x 2225 mm	6210 x 2225 mm	2 x 6210 x 2225 mm
OVERALL DIMENSIONS WITH LIGHT BARRIERS	5680 x 7208 mm	5680 x 9242 mm	15200x5400 mm

# BREMBANA MILESTONE S

## BULK AND TECHNICAL DATA

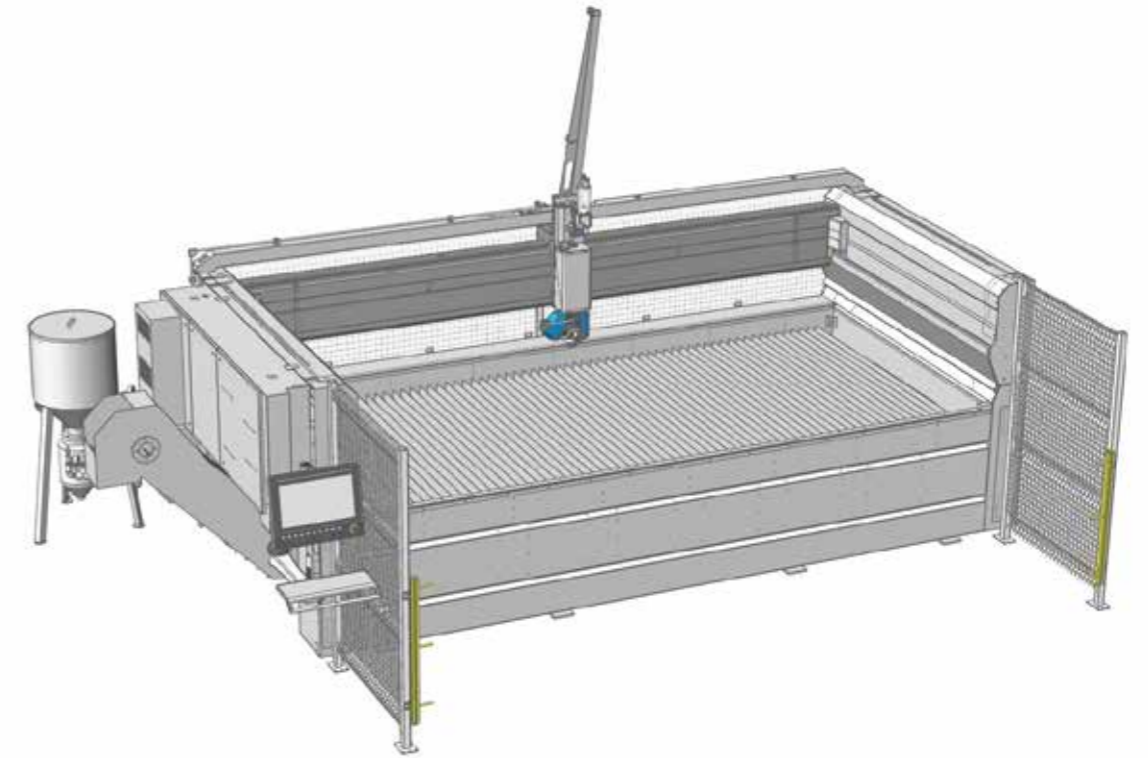

BREMBANA MILESTONE S: TECHNICAL DATA		
MODEL	1730	2040
X AXIS	3000 mm (2 head) 3300 mm (1 head)	4000 mm (2 head) 4250 mm (1 head)
Y AXIS	1700 mm	2000 mm
Z AXIS	350 mm (200 mm with 5-axis head)	350 mm (200 mm with 5-axis head)
B AXIS	+/- 60°	+/- 60°
SUPPORT PLANE	3700 x 2050 mm	4650 x 2050 mm
OVERALL DIMENSIONS WITH LIGHT BARRIERS	5010 x 3600 mm	5960 x 3900 mm
WEIGHT (EMPTY)	3600 kg	4000 kg

# BREMBANA PROLINE

## BULK AND TECHNICAL DATA



# BREMBANA AQUATEC

## BULK AND TECHNICAL DATA



### BREMBANA PROLINE: TECHNICAL DATA

MODEL	2040
X AXIS STROKE (1 HEAD)	4250 mm
Y AXIS STROKE	2000 mm
Z AXIS STROKE (3-AXIS HEAD)	300 mm
Z AXIS STROKE (5-AXIS HEAD)	200 mm
C AXIS (5 AXIS ONLY)	Infinite
B AXIS (5 AXIS ONLY)	+/- 62°
XY AXIS RAPID SPEED	40000 mm/min
WORKTABLE SIZE	4820 x 2220 mm
WORKTABLE LOAD CAPACITY	1000 kg/m2
FOOTPRINT LXPXH	7290x 3480 x 3900 mm
WEIGHT MAX (EMPTY)	8000 kg

### BREMBANA AQUATEC: TECHNICAL DATA

MODEL*	2040	QUICK	ACCELERATIONS	6040 TWIN	QUICK	ACCELERATIONS
X AXIS	4020 mm	54 m	2 m	4000 mm	72 m/min	2 m/s2
Y AXIS	2650 mm	54 m	2 m	6650 mm	72 m/min	2 m/s2
Z AXIS	530 mm	12,6 m	1 m	530 mm	28 m/min	1 m/s2
B AXIS	± 60°	17200 °	1450 °	± 61°	13400 °/min	850 °/sec2
C AXIS	± 340°	13400 °	850 °	± 340°	17200 °/min	1450 °/sec2
WORKABLE AREA	2000 x 4000 mm			front area 4000 x 2000 mm rear area 4000x2000		
OVERALL DIMENSIONS	5886 x 4039 mm senza fotocellule			9800x10300 mm withour pressure intensifiers		

# PRESSURE MULTIPLIERS

## TECHNICAL DATA

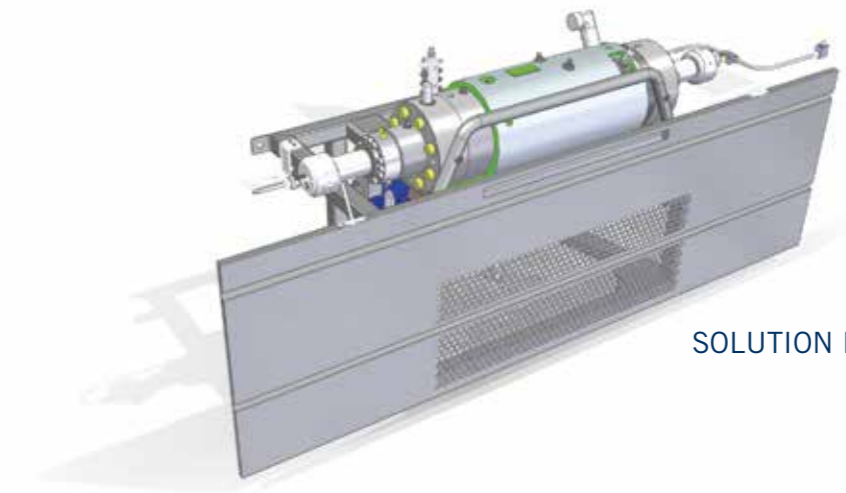

SOLUTION FOR PROLINE

### BREMBANA JETPOWER EVO: TECHNICAL DATA

MODEL	JETPOWER EVO 40 HP	JETPOWER EVO 60 HP
POWER	22,5 kW	45 kW
MULTIPLIERS	2	3
MAX FLOW PRESSURE	4150 bar	4150 bar
MAX WATER PRESSURE	2,7 L/min	5 L/min
MAX ORIFICES DIAMETER	0,28 mm	0,40 mm
VOLTAGE	400V +/- 5% 50-60 Hz (Different voltages and frequencies on request)	

### BREMBANA GREENJET EVO: TECHNICAL DATA

MODEL	GREENJET 4159	GREENJET 4159 SA
POWER	34 kW	34 kW
MULTIPLIERS	2	2
MAX FLOW PRESSURE	4139 bar	4139 bar
MAX WATER PRESSURE	5 L/min	5 L/min
MAX ORIFICES DIAMETER	0,4 mm	0,4 mm
VOLTAGE	400V +/- 5% 50-60 Hz (Different voltages and frequencies on request)	

# CMS connect the IoT platform perfectly integrated with the latest-generation CMS machines

CMS Connect is able to offer customised micro services through the use of IoT Apps that support the daily activities of industry operators - improving the availability and use of machines or systems. The platform displays, analyses and monitors all data from connected machines. The data collected by the machines in real time become useful information increase machine productivity, reduce operating and maintenance costs and cut energy costs.



# CMS active a revolutionary interaction with your CMS machine

Cms active is our new interface. The same operator can easily control different machines as the CMS Active interfaces maintain the same look&feel, icons and iteration approach.



## APPLICATIONS

**SMART MACHINE:** Section designed for the continuous monitoring of machine operation, with information on:

**Status:** machine status overviews. The representations provided allow machine availability to be checked - to identify possible bottlenecks in the production flow.

**Monitoring:** instantaneous, live display of the operation of the machine and its components, of currently running programs and potentiometers;

**Production:** list of machine programs run within a given timeframe with best time and average running time;

**Alarms:** active and historical warnings.

### SMART MAINTENANCE

This section provides a first approach to predictive maintenance by sending notifications when machine components indicate a potentially critical state associated with reaching a certain threshold. In this way, it is possible to take action and schedule maintenance services, without any downtime.

### SMART MANAGEMENT

Section designed for KPI presentation for all the machines connected to the platform. The indicators provided assess of the availability, productivity and

efficiency of the machine and the quality of the product.

### MAXIMISED SECURITY

CMS Connect uses the standard OPC-UA communication protocol, which guarantees the encryption of data at Edge interface level. CMS Connect's Cloud and DataLake levels meet all state-of-the-art cyber-security requirements. Customer data are encrypted and authenticated to ensure total protection of sensitive information.

## ADVANTAGES

- ✓ Optimisation of production performance
- ✓ Diagnostics to support components warranty optimisation
- ✓ Productivity increase and downtime reduction
- ✓ Improvement of quality control
- ✓ Maintenance costs down

### EASY OF USE

The new interface has been especially developed and optimized to be immediately used via touch screen. Graphics and icons have been redesigned for user-friendly and comfortable navigation.

### ADVANCED ORGANIZATION OF PRODUCTION

CMS Active enables configuring different users with different roles and responsibilities according to the operation mode of the machining center (e.g.: operator, maintenance man, administrator, ...).

It is also possible to define the work shifts on the machining center and then survey activities, productivity and events that have occurred in each shift.

### ABSOLUTE QUALITY OF THE FINISHED WORKPIECE

With CMS Active the quality of the finished workpiece is no longer jeopardized by worn-out tools. The new Tool Life Determination system of CMS Active sends warning messages when the tool life is running out and recommends its replacement at the most appropriate time.

### TOOL SET-UP? NO PROBLEM!

CMS Active guides the operator during the tool magazine set-up phase, also allowing for the programs to be run.



## THE MOST ADVANCED SKILLS AND KNOW-HOW IN THE FIELDS OF MACHINERY AND INDUSTRIAL COMPONENTS

A technological world leader in processing a wide variety of materials: wood, plastic, glass, stone, metal and composites. The Group companies, operating throughout the world, are reliable partners of leading companies in various market sectors, including the furniture, construction, automotive, aerospace, ship-building and plastic processing industries.

SCM Group coordinates, supports and develops a system of industrial excellence in 3 large highly specialized production centres employing more than 4.000 workers and operating in all 5 continents.

### INDUSTRIAL MACHINERY

Standalone machines, integrated systems and services dedicated to the processing of a wide range of materials.



Woodworking technologies



Technologies for advanced materials, plastic, stone, glass and metals processing



### INDUSTRIAL PARTS

Technological components for Group and third party machines and plants and for the mechanical industry



Electrospindle and technological components



Electrical panels



Metalworking and mechanical machining



Cast Iron

### SCM GROUP IN BRIEF

**+700**  
Milioni/Euro  
in consolidated  
turnover

**+4.000**  
people  
in Italy and abroad

**3** main  
production  
centres

A presence on **5**  
continents that is  
direct and widespread

**7%**  
of turnover  
invested in  
R&D

# THE RANGE OF CMS STONE TECHNOLOGY

# FOR STONE PROCESSING

## 5-AXIS BRIDGE SAWS

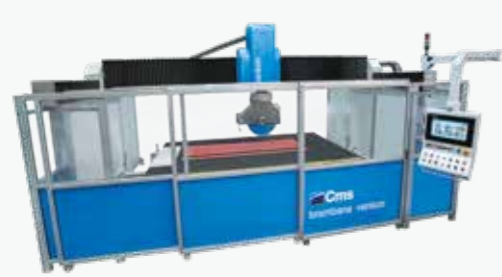

**BREMBANA VENKON**



**BREMBANA KOSMOS**

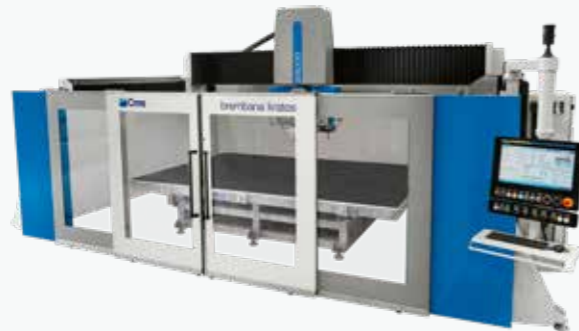

**KRATOS**

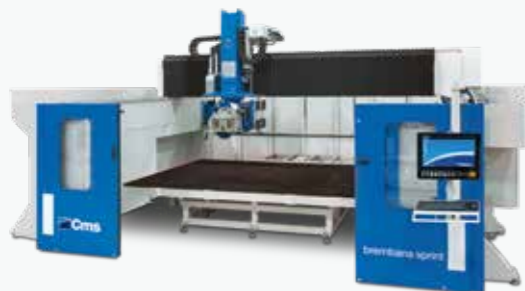

**BREMBANA SPRINT**



**BREMBANA GIXA**

## SAW-JET MACHINES



**BREMBANA KOSMOS JET**



**BREMBANA FORMAX JET / SPRINT JET**

## CNC MACHINING CENTERS



**BREMBANA ELECTA**



**BREMBANA SPEED**



**BREMBANA SPEED TR**



**BREMBANA KARTESIA**



**BREMBANA MAXIMA**



**BREMBANA G-REX**

## WATERJET CUTTING SYSTEMS AND PRESSURE INTENSIFIERS



**BREMBANA EASYLINE**



**BREMBANA MILESTONE S**



**BREMBANA PROLINE**

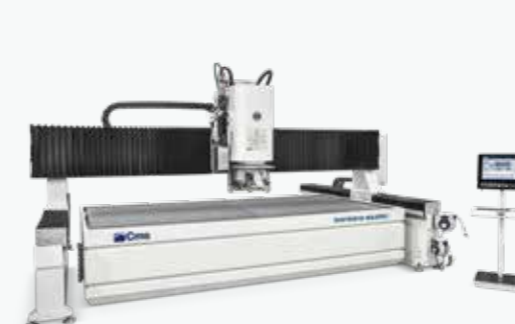

**BREMBANA AQUATEC**



**BREMBANA  
JET POWER EVO**



**BREMBANA  
GREENJET EVO**



**C.M.S. SPA**  
via A. Locatelli, 123 - 24019 Zogno (BG) - IT  
Tel. +39 0345 64111  
[info@cms.it](mailto:info@cms.it)  
[cms.it](http://cms.it)

a company of **scm**group